



UW LINEAIR SPECIALIST

VOOR IEDERE INDUSTRIËLE TOEPASSING
EEN INDIVIDUELE OPLOSSING



Componenten voor
lineaire bewegingen



Snel geleverd vanuit
eigen voorraad



Advies, ontwerp, calculaties
en een eigen werkplaats

Nederland

T: +31 (0)318-554615

E: info@lmsystems.nl

www.lmsystems.nl

België

T: +32 (0)2 252 4745

E: info@lmsystems.be

www.lmsystems.be

Would you align, please?

No, I don't need!
I am Self-Aligning!

27

Self-Aligning Linear Bushing(LMES, LMBS)

High Capacity Self-Aligning Linear Bushing - SUPERBALL

Higher Load Ratings and Travel Life

Specially designed ball plate is made of Hardened steel, and the precisely ground groove is slightly larger than the ball size, which provides greater contact area between the ball and the ball plate. In addition, this design provides 3 times higher load ratings and 27 times longer travel life compared to conventional Linear Bushing.

Self-Alignment

Ball plate has a convex shape to provide a pivot point at the center, which allows Self Alignment up to $0^{\circ}.5$. This Self Alignment capability eliminates any possibility of edge pressure caused by inaccurate machining, errors on mounting, or shaft deflection. Moreover, it obtains uniform load distribution and low friction motion.

Smooth and Silent Running

SUPERBALL has extremely smooth running due to the uniquely designed ball retainer and the outer sleeve. They are made of Engineering Polymer, which has light weight, low friction, and high wear-resistance. Due to them, the smooth and silent running can be obtained..

Clearance Adjustment

SUPERBALL's ball plates are designed to float in the outer sleeve. This allows clearance between the balls and shaft to be adjusted for the best application environment by using with the housing.

Interchangeability

SUPERBALL is designed to be fully Interchangeable with conventional linear bushing.

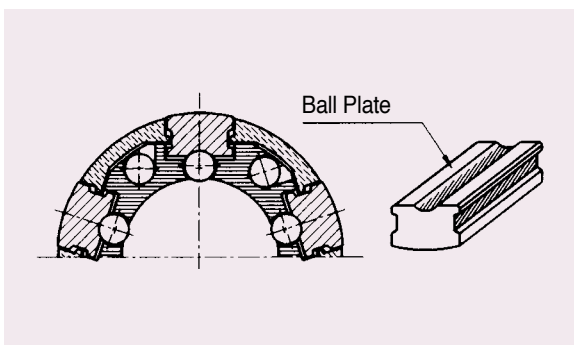

Fig3. Cross-section of SUPERBALL

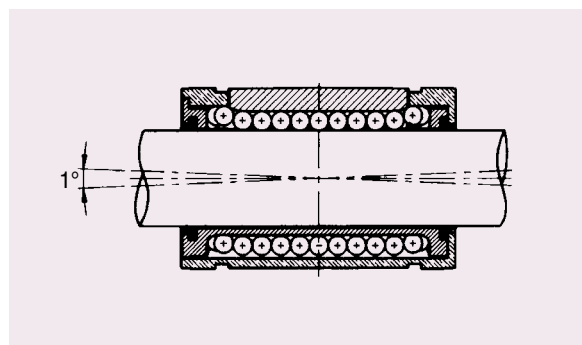

Fig4. SUPERBALL's self-alignment feature

Cost Effectiveness

Lower cost on installation

Self-Alignment feature can compensate the inaccurate machining of the base, so less installation time and cost can be obtained.

Higher load rating and longer travel life

Compared to the same size conventional linear bushings, SUPPERBALL will offer higher load rating and longer travel life.

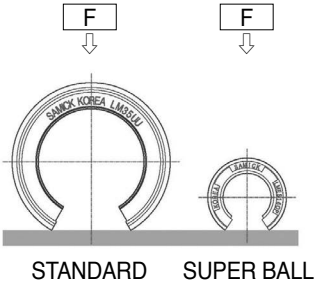

Reduction of material cost

SUPPERBALL's higher load rating enables the use of smaller components, and reducing material cost.

Energy saving

SUPPERBALL is designed with lightweight, lower inertia, and low friction, so it enables the moving parts to have rapid motion with lower driving power.

Load Ratings and Travel Life

SUPPERBALL's load ratings give an influence to travel life with load direction, ball circuit orientation, and hardness of the shaft.

	Orientation of Balls		
No. of Ball Row	4 Row	5 Row	6 Row
Max. Load			
Equation	$F = 1.41 \times C$	$F = 1.46 \times C$	$F = 1.26 \times C$
Min. Load			
Equation	$F = C$	$F = C$	$F = C$

Basic Dynamic load rating(C) and travel life

The travel life of a Linear Bushing is determined largely by the quality of the shaft. The Basic Dynamic load rating is maximum continuous load that can be applied to the Linear Bushing with 90% of reliability achieving after 50km operation under normal conditions. The nominal travel life can be calculated by follow equation.

$$L = \left[\frac{C}{P} \right]^3 \times 50$$

$$L_{100} = \left[\frac{C_{100}}{P} \right]^3 \times 100$$

L : Nominal life (basis 50km, unit : km)
 L₁₀₀ : Nominal life (basis 100km, unit : km)
 C : Basic dynamic load rating (basis : 50km, unit : N)
 C₁₀₀ : Basic dynamic load rating (basis : 100km, unit : N)
 P : Applied load

Practically, other factors will affect the life as follows

$$L = \left[\frac{f_H \times f_T \times f_c}{f_w} \times \frac{C}{P} \right]^3 \times 50$$

$$L_{100} = \left[\frac{f_H \times f_T \times f_c}{f_w} \times \frac{C_{100}}{P} \right]^3 \times 100$$

f_w : Load factor
 f_H : Hardness factor
 f_T : Temperature factor
 f_c : Contact factor

From the above equations, the stroke and frequency are constant, the Travel Life can be calculated by following equation

$$L_h = \frac{L \times 10^6}{2 \times l_s \times N_l \times 60}$$

L_h : Travel life(hour)
 l_s : Stroke(mm)
 N_l : Number of strokes per minute(cpm)

Examples of Calculation and Choosing a proper SUPERBALL

The Maximum applied load and the travel life are the most important factor for choosing a proper Linear Bushing size. Below are the sample calculation of the expecting travel life and choosing of proper Linear Bushing size.

< Working conditions >

- | | | | |
|---------------------------------|------------------------|------------------|---------------------------------------------|
| - Applied load | : 250N (P) | - Stroke | : 250mm (l _s) |
| - Number of strokes per minutes | : 60 (N _l) | - Shaft Hardness | : H _R C60 (f _H = 1.0) |
| - Operating speed | : 30m/min | | |

$$\begin{aligned} \text{Operating Speed } V &= 2 \times l_s \times N_l \\ &= 2 \times 250 \times 60 \\ &= 30,000 \text{mm/min (} f_w = 1.6 \text{)} \end{aligned}$$

Other factors (f_c, f_T) are considered as 1.0

Calculation of expected travel life

Since, basic dynamic load rating is based on travel life of 50km and assuming all other factors as 1.0, you can choose the Linear Bushing size that you can expected Travel life. Let's try LMES20UU with the above working conditions.

$$L = \left[\frac{1.0 \times 1.0 \times 1.0}{1.6} \times \frac{2,580}{250} \right]^3 \times 50 \quad L_h = \frac{13,417 \times 10^6}{2 \times 250 \times 60 \times 60}$$

$$\cong 13,417 \text{ km} \quad \cong 7,454 \text{ hours}$$

Choosing proper Linear Bushing

Let's assume our design travel life is 15,000hours,

$$L = 15,000 \times 2 \times 250 \times 10^{-6} \times 60 \times 60 = 27,000\text{km}$$

$$C = \frac{250 \times 1.6}{1.0 \times 1.0 \times 1.0} \times \sqrt[3]{\frac{27,000}{50}} = 3,257\text{N}$$

Therefore, the proper SUPERBALL for above condition is LMES25UU which has 3800N as the Basic dynamic load rating.

Housing and Shaft

Housing

For SUPERBALL's application, Housing is required. Tolerance of Housing bore will affect the life and the accuracy of application. See the below Table However, if the tolerance of housing is H7, tight fitting can be occurred at both ends of outer- sleeves in case of LMES type

Table9. Housing and tight fitting

Part number(mm)	LMES10	LMES12	LMES16	LMES20	LMES25	LMES30	LMES40	LMES50	
Inner diameter(mm)	19	22	26	32	40	47	62	75	
Tolerance(H7)	+0.021 0			+0.025 0			+0.030 0		
Part number(inch)	LMBS4	LMBS6	LMBS8	LMBS10	LMBS12	LMBS16	LMBS20	LMBS24	LMBS32
Inner diameter(inch)	0.5	0.625	0.875	1.125	1.25	1.5625	2	2.375	3
Tolerance(H7)	+0.0007 0		+0.0008 0		+0.0010 0		+0.0012 0		

LM Shaft

Because the balls in SAMICK SUPERBALL as rolling elements are running directly on the shaft surface, the hardness, surface finish, and tolerance of shaft will largely affect on the traveling performance of SUPERBALL. The shaft must be manufactured with following conditions;

1) Hardness

The hardness must be HRC 58 to 64. The shaft with hardness less than HRC58 will lead decreasing of travel life and permissible load.

2) Surface Finishing

The surface finishing must be 1.6S or better for smooth operation.

3) Tolerance

The correct tolerance of the shaft diameter is recommended. See the below table.

Table10. Shaft and tight fitting

Part number (mm)	LMES10	LMES12	LMES16	LMES20	LMES25	LMES30	LMES40	LMES50	
Diameter (mm)	10	12	16	20	25	30	40	50	
Tolerance (h6)	0 -0.009	0 -0.011	0 -0.011	0 -0.013	0 -0.013	0 -0.013	0 -0.016	0 -0.016	
Part number (inch)	LMBS4	LMBS6	LMBS8	LMBS10	LMBS12	LMBS16	LMBS20	LMBS24	LMBS32
Diameter (inch)	0.25	0.375	0.500	0.625	0.750	1.000	1.250	1.500	2.000
Tolerance (g6)	-0.0002 -0.0006	-0.0002 -0.0006	-0.0002 -0.0007	-0.0002 -0.0007	-0.0003 -0.0008	-0.0003 -0.0008	-0.0004 -0.0010	-0.0004 -0.0010	-0.0004 -0.0012

○ PART NUMBER NOTATION

● Self-aligning Linear Bushing

LM ES 16 UU OP - N S

● SAMICK Linear Bushing

● Standard Selection(Europe, US)

ES	Metric series (mm)
BS	Inch series (inch)

● Nominal Shaft Diameter

10~50mm	Metric (mm)
#4~#32	Inch Series

● Seal

Blank	No Seal
UU	Both Side Seal
U	One Side Seal

● Sloting Type

Blank	Standard type
OP	Open type(for support rail)

● Corrosion resistance type

Blank	Standard(SUJ2)
N	Electroless nickel plating
C	Chrome plating
M*1	Stainless steel

● Ball type (material)

Blank	High carbon bearing steel ball(Standard)
S	Stainless steel ball

★1 LMES10-12, LMBS4-6-8 Only

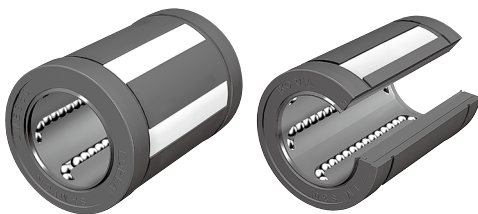

LMES Self-Aligning Linear Bushing

● Drawing

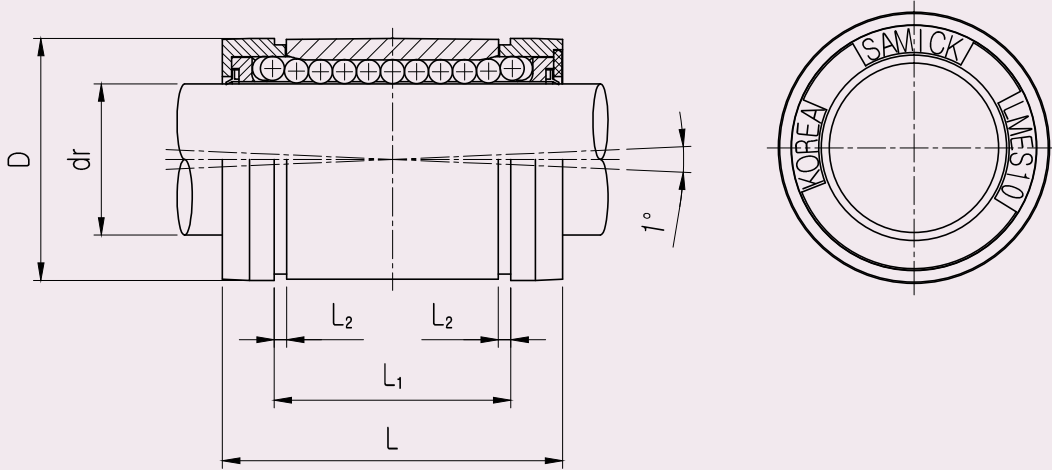

● Part Number Notation

LMES 20 UU - N S

- Self-aligning Linear Bushing(European standard)
- Nominal Shaft Diameter
- Seal

Blank	No Seal
UU	Both Side Seal
U	One Side Seal

- Corrosion resistance type

Blank	Standard(SUJ2)
N	Electroless nickel plating
C	Chrome plating
M ^{★1}	Stainless steel

- Ball type (material)

Blank	High carbon bearing steel ball(Standard)
S	Stainless steel ball



★1 LMES 10-12 Only

LMES Self-Aligning Linear Bushing

PART NUMBER	WORKING dr.		D* ¹ mm	L ±0.2	L ₁ ±0.2	L ₂ min	BASIC LOAD RATING(N)		NO. OF BALL CIRCUIT	WEIGHT (gf)
	dr. (mm)	BORE DIAMETER CLEARANCE					DYNAMIC (C) ^{*2}	STATIC (C ₀)		
LMES10UU	10	+0.008 0	19	29	21.7	1.35	750	550	5	17
LMES12UU	12		22	32	22.7	1.35	1230	1100	5	23
LMES16UU	16	+0.009 +0.001	26	36	24.7	1.35	1550	1250	5	28
LMES20UU	20		32	45	31.3	1.65	2580	1670	6	61
LMES25UU	25	+0.011 +0.001	40	58	43.8	1.90	3800	2750	6	122
LMES30UU	30		47	68	51.8	1.90	4710	2800	6	185
LMES40UU	40	+0.013 +0.002	62	80	60.4	2.20	6500	5720	6	360
LMES50UU	50		75	100	77.4	2.70	11460	7940	6	580

★1 Based on nominal housing bore

★2 Dynamic load rating is based on the nominal life of 50km. In case of 100km, C on the table need to be divide by 1.26

Ex) 50km basis dynamic load rating of LMES12 C= 1230N

100km basis dynamic load rating of LMES12 C₁₀₀ = 1230 / 1.26 =976.20N

★3 Main unit : mm

★4 LMES10, LMES12 only with stainless steel ball plate

★5 1N ≒0.102kgf

LMES_OP Self-Aligning Linear Bushing

● Drawing

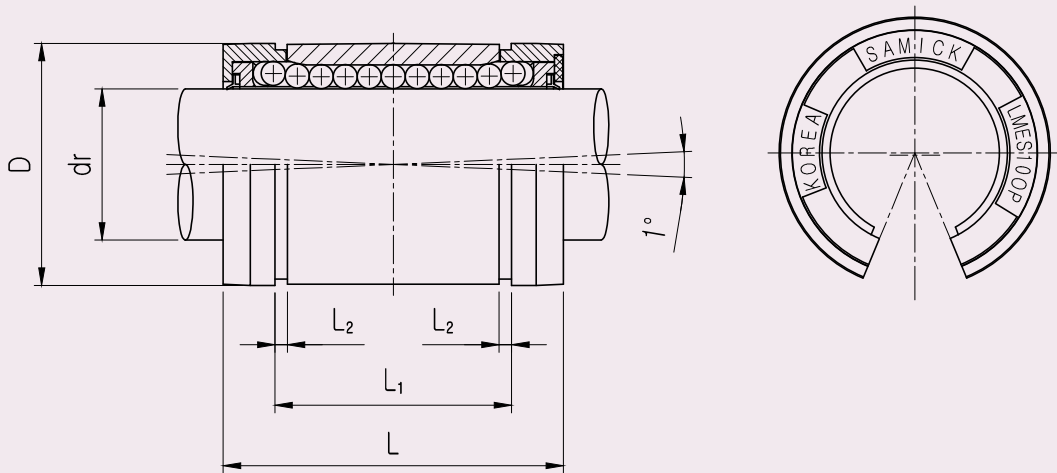

● Part Number Notation

LMES 20 UU OP - N S

- Self-aligning Linear Bushing(Europeanstandard)
- Nominal Shaft Diameter
- Seal

Blank	No Seal
UU	Both Side Seal
U	One Side Seal

- Open type Linear Bushing
- Corrosion resistance type

Blank	No-plaiting(Standard)
N	Electroless nickel plating
C	Chrome plating
M ^{★1}	Stainless steel

- Ball type (material)

Blank	High carbon bearing steel ball(Standard)
S	Stainless steel ball

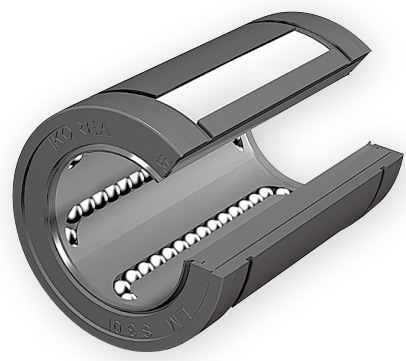

★1 LMES12 OP Only

LMES_OP Self-Aligning Linear Bushing

PART NUMBER	WORKING dr.		D* ¹ mm	L ±0.2	L ₁ ±0.2	L ₂ min	h	θ	F	G	J	BASIC LOAD RATING(N)		NO. OF BALL CIRCUIT	WEIGHT (gf)
	dr. (mm)	BORE DIAMETER CLEARANCE										DYNAMIC (C) ^{*2}	STATIC (C ₀)		
LMES12UU OP	12	+0.008 0	22	32	22.7	1.35	6.5	66	3	-	0.7	1290	1260	4	18
LMES16UU OP	16	+0.009 +0.001	26	36	24.7	1.35	9	68	3	-	0.7	1640	1320	4	22
LMES20UU OP	20		32	45	31.3	1.65	9	55	3	-	0.9	2630	1720	5	51
LMES25UU OP	25	+0.011 +0.001	40	58	43.8	1.90	11.5	57	3	1.5	1.4	3910	2850	5	102
LMES30UU OP	30		47	68	51.8	1.90	14	57	3	2.0	2.2	4850	2900	5	155
LMES40UU OP	40	+0.013 +0.002	62	80	60.4	2.20	19.5	56	3	1.5	2.7	6700	5900	5	300
LMES50UU OP	50		75	100	77.4	2.70	22.5	54	5	2.5	2.3	11700	8100	5	480

※ Fixing hole position

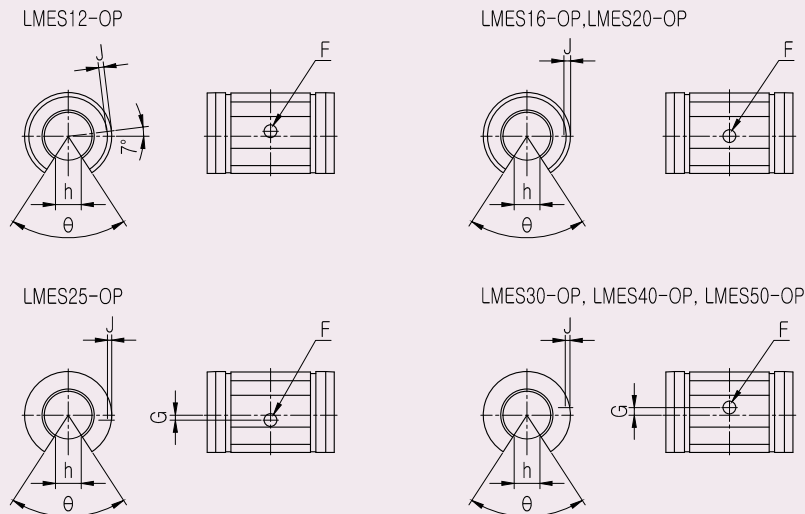

- ★1 Based on nominal housing bore
- ★2 Dynamic load rating is based on the nominal life of 50km. In case of 100km, C on the table need to be divide by 1.26
Ex) 50km basis dynamic load rating of LM12 C= 1290N
100km basis dynamic load rating of LM12 C₁₀₀= 1290 / 1.26 =1023.80N
- ★3 Main unit : mm
- ★4 LMES10, LMES12 only with stainless steel ball plate
- ★5 1N ≒0.102kgf

LMBS Self-Aligning Linear Bushing

● Drawing

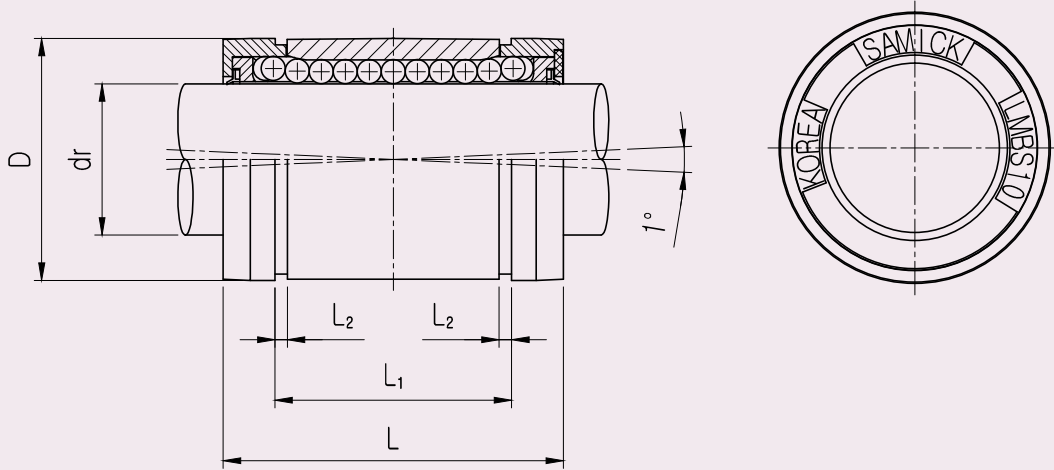

● Part Number Notation

LMBS 20 UU - N S

- Self-aligning Linear Bushing(inch type)
- Nominal Shaft Diameter
- Seal

Blank	No Seal
UU	Both Side Seal
U	One Side Seal

- Corrosion resistance type

Blank	No-plating(Standard)
N	Electroless nickel plating
C	Chrome plating
M ^{★1}	Stainless steel

- Ball type (material)

Blank	High carbon bearing steel ball(Standard)
S	Stainless steel ball



★1 LMBS 4-6-8 Only

LMBS Self-Aligning Linear Bushing

PART NUMBER	WORKING dr.		D* ¹ inch	L	L ₁	L ₂ min	BASIC LOAD RATING(N)		NO. OF BALL CIRCUIT	WEIGHT (gf)
	dr. (inch)	BORE DIAMETER CLEARANR					DYNAMIC (C) ^{*2}	STATIC (Co)		
LMBS4UU	0.2500	0 -0.0005	0.5000	0.750/0.735	0.511/0.501	0.039	57	49	4	0.01
LMBS6UU	0.3750		0.6250	0.875/0.860	0.699/0.689	0.039	78	66	4	0.02
LMBS8UU	0.5000		0.8750	1.250/1.230	1.032/1.012	0.050	210	190	4	0.05
LMBS10UU	0.6250		1.1250	1.500/1.480	1.105/1.095	0.056	290	340	5	0.08
LMBS12UU	0.7500		1.2500	1.625/1.605	1.270/1.250	0.056	500	430	6	0.14
LMBS16UU	1.0000		1.5625	2.250/2.230	1.884/1.864	0.070	820	780	6	0.29
LMBS20UU	1.2500	0 -0.0006	2.0000	2.625/2.600	2.004/1.984	0.068	1240	1270	6	0.40
LMBS24UU	1.5000		2.3750	3.000/2.970	2.410/2.390	0.086	1510	1540	6	0.80
LMBS32UU	2.0000	0 -0.0008	3.0000	4.000/3.960	3.193/3.163	0.105	2230	2580	6	1.38

★1 Based on nominal housing bore

★2 Dynamic load rating is based on the nominal life of 50km. In case of 100km, C on the table need to be divided by 1.26

Ex) 50km basis dynamic load rating of LM12 C = 500 ℓ bf

100km basis dynamic load rating of LM12 C₁₀₀ = 500 / 1.26 = 396.83 ℓ bf

★3 Main unit : inch

★4 LMBS4, 6, 8 only with stainless steel ball plate

★5 1 ℓ bf = 0.453kgf

LMBS_OP Self-Aligning Linear Bushing

● Drawing

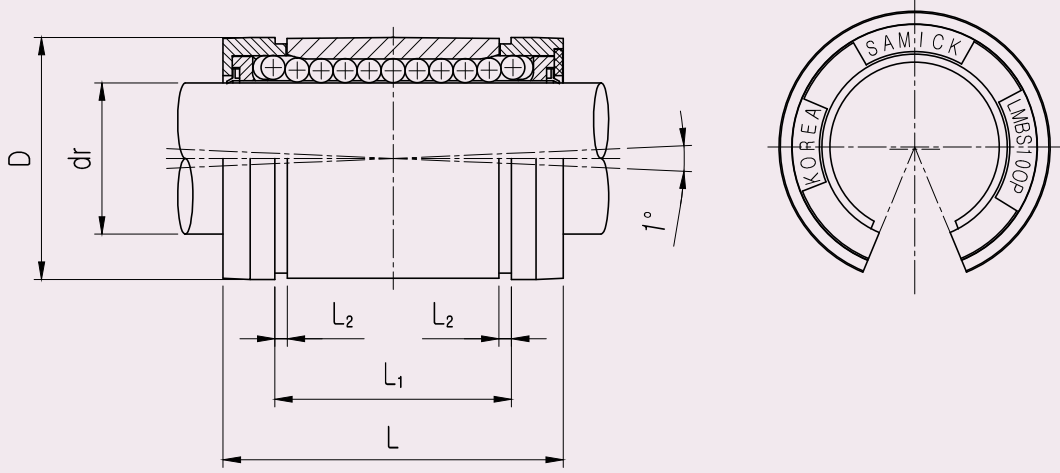

● Part Number Notation

LMBS 20 UU OP - N S

- Self-aligning Linear Bushing(inch type))
- Nominal Shaft Diameter
- Seal

Blank	No Seal
UU	Both Side Seal
U	One Side Seal

- Open type
- Corrosion resistance type

Blank	Standard(SUJ2)
N	Electroless nickel plating
C	Chrome plating
M ^{★1}	Stainless steel

- Ball type (material)

Blank	High carbon bearing steel ball(Standard)
S	Stainless steel ball

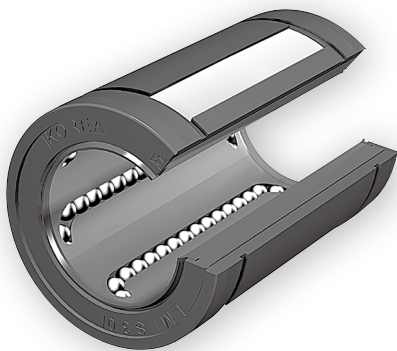

★1 LMBS8 OP type only

LMBS_OP Self-Aligning Linear Bushing

PART NUMBER	WORKING dr.		D* ¹ inch	L	L ₁	F	G	J	L ₂ min	h	BASIC LOAD RATING(N)		NO. OF BALL CIRCUIT	WEIGHT (gf)
	dr. (inch)	BORE DIAMETER CLEARANR									DYNAMIC (C) ^{*2}	STATIC (C ₀)		
LMBS8UU OP	0.5000	0 -0.0005	0.8750	1.250/1.230	1.032	0.14	0.63	Thru	0.050	0.32	210	190	3	0.03
LMBS10UU OP	0.6250		1.1250	1.500/1.480	1.105	0.11	0.13	0.039	0.056	0.38	320	340	4	0.06
LMBS12UU OP	0.7500		1.2500	1.625/1.605	1.270	0.14	0.13	0.059	0.056	0.43	510	430	5	0.11
LMBS16UU OP	1.0000		1.5625	2.250/2.230	1.884	0.14	0.13	0.047	0.070	0.56	830	780	5	0.21
LMBS20UU OP	1.2500	0 -0.0006	2.0000	2.625/2.600	2.004	0.20	0.19	0.090	0.068	0.63	1250	1270	5	0.35
LMBS24UU OP	1.5000		2.3750	3.000/2.970	2.410	0.20	0.19	0.090	0.086	0.75	1520	1540	5	0.67
LMBS32UU OP	2.0000	0 -0.0008	3.0000	4.000/3.960	3.193	0.27	0.31	Thru	0.105	1.00	2250	2580	5	1.10

* Fixing hole position

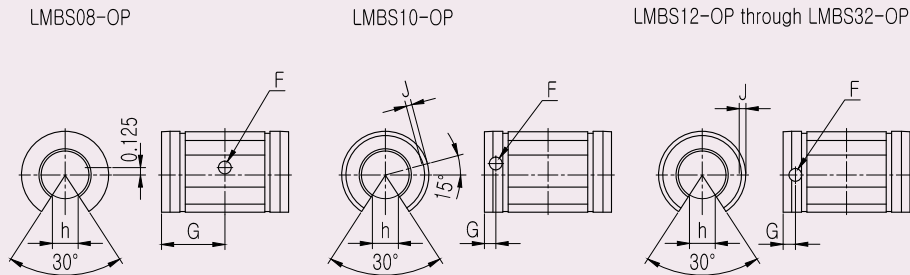

- ★1 Based on nominal housing bore
- ★2 Dynamic load rating is based on the nominal life of 50km. In case of 100km, C on the table need to be divided by 1.26
Ex) 50km basis dynamic load rating of LMBS12 C = 510 ℓ bf
100km basis dynamic load rating of LMBS12 C₁₀₀ = 510 / 1.26 = 404.76 ℓ bf
- ★3 Main unit : inch
- ★4 LMBS8 OP only with stainless steel ball plate
- ★5 1 ℓ bf = 0.453kgf



Wij ontzorgen bij
ontwerp en calculaties



Eigen voorraad dus
snel en direct leveren



Wij gaan verder waar
de catalogus ophoudt

Gildetrom 25 3905 TB Veenendaal **Nederland**
T: +31 (0)318-554615 | E: info@lmsystems.nl
www.lmsystems.nl

Leuvensesteenweg 613 | B-1930 Zaventem **België**
T: +32 (0)2 252 4745 | E: info@lmsystems.be
www.lmsystems.be