



UW LINEAIR SPECIALIST

VOOR IEDERE INDUSTRIËLE TOEPASSING
EEN INDIVIDUELE OPLOSSING



Excellente service



Klantspecifieke assemblage



Voorraadhoudend



Leveringsgraad 99,5%

Nederland

T: +31 (0)318-554615

E: info@lmsystems.nl

www.lmsystems.nl

België

T: +32 (0)2 252 4745

E: info@lmsystems.be

www.lmsystems.be

SRS



Caged Ball LM Guide Miniature Type Model SRS

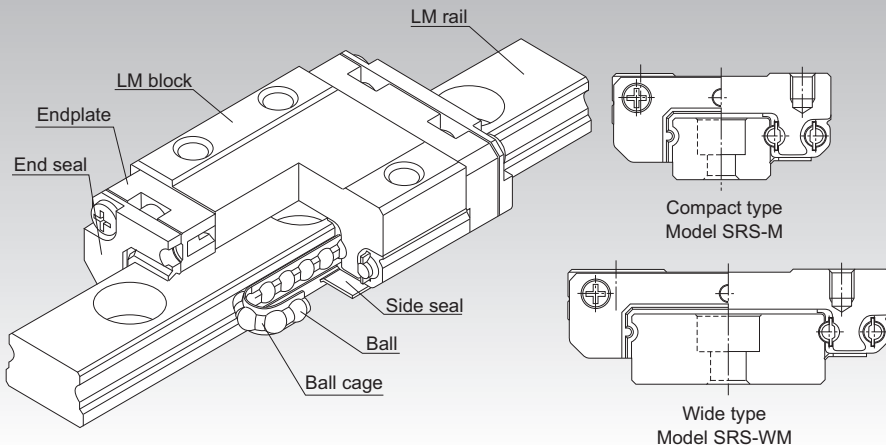

*For the ball cage, see **A1-88**.

Point of Selection **A1-10**

Point of Design **A1-454**

Options **A1-477**

Model No. **A1-543**

Precautions on Use **A1-549**

Accessories for Lubrication **A24-1**

Mounting Procedure and Maintenance **B1-89**

Equivalent moment factor **A1-43**

Rated Loads in All Directions **A1-59**

Equivalent factor in each direction **A1-61**

Radial Clearance **A1-71**

Accuracy Standards **A1-83**

Shoulder Height of the Mounting Base and the Corner Radius **A1-469**

Permissible Error of the Mounting Surface **A1-471**

Flatness of the Mounting Surface **A1-472**

Dimensions of Each Model with an Option Attached **A1-491**

Structure and Features

Caged Ball LM Guide model SRS has a structure where two raceways are incorporated into the compact body, enabling the model to receive loads in all directions, and to be used in locations where a moment is applied with a single rail. In addition, use of ball cages eliminates friction between balls, thus achieving high speed, low noise, acceptable running sound, long service life, and long-term maintenance-free operation.

[Low Dust Generation]

Use of ball cages eliminates friction between balls and retains lubricant, thus achieving low dust generation. In addition, the LM block and LM rail use stainless steel, which is highly resistant to corrosion.

[Compact]

Since SRS has a compact structure where the rail cross section is designed to be low and that contains only two rows of balls, it can be installed in space-saving locations.

[Lightweight]

Since part of the LM block (e.g., around the ball relief hole) is made of resin and formed through insert molding, SRS is a lightweight, low inertia type of LM Guide.

Types and Features

Model SRS5M

SRS5 is the smallest caged ball LM guide.

Specification Table⇒ **A1-154**

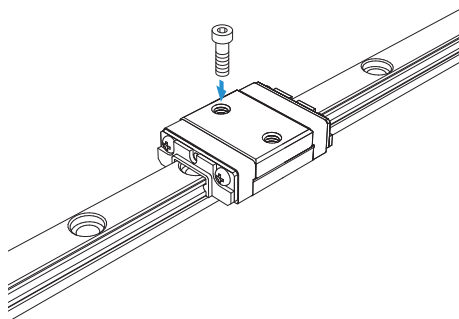

Model SRS-5N

Overall LM block length (L) is greater than for model SRS5M; load rating and permissible moment are higher as well.

Specification Table⇒ **A1-154**

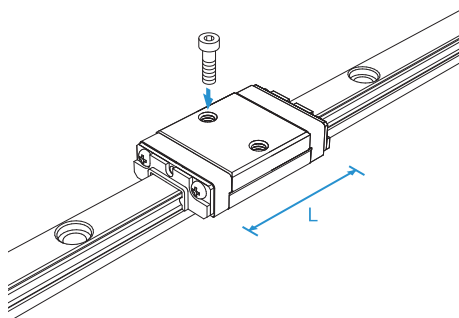

Model SRS5WM

This model has a larger overall LM block length (L), width (W), rated load and permissible moment than model SRS5M.

Specification Table⇒ **A1-158**

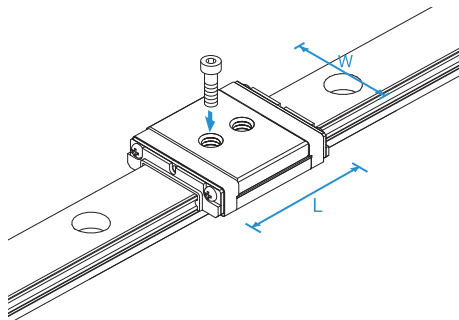

Model SRS-5WN

Overall LM block length (L) is greater than for model SRS5WM; load rating and permissible moment are higher as well.

Specification Table⇒ **A1-158**

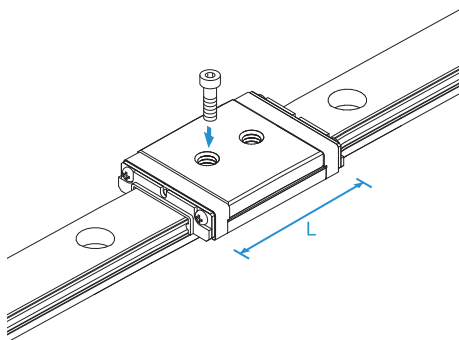

LM Guide

Model SRS-S

Overall LM block length (L) is less than that of model SRS-M.

Specification Table⇒ **A1-154**

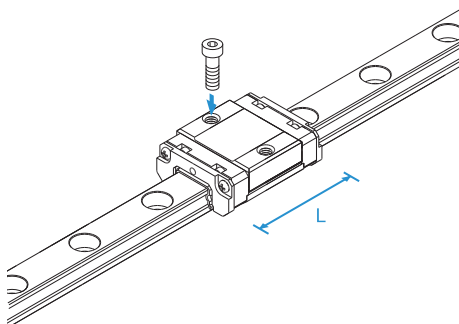

Model SRS-WS

Has a longer overall LM block length (L), a greater width and a larger rated load and permissible moment than SRS-S.

Specification Table⇒ **A1-158**

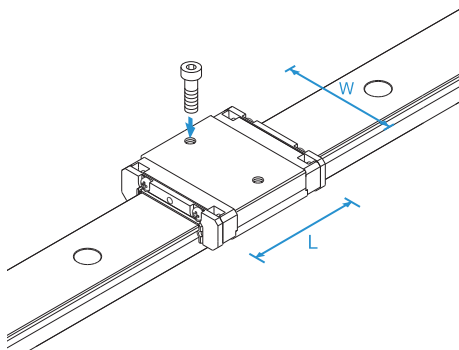

Model SRS-M

A standard type of SRS.

Specification Table⇒ **A1-154**

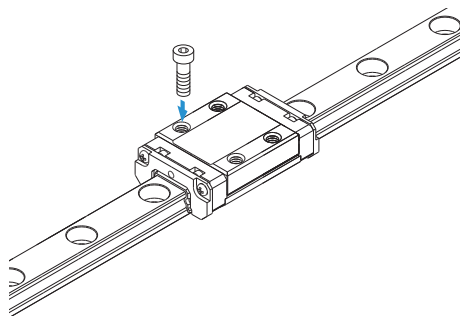

Model SRS-WM

Has a longer overall LM block length (L), a greater width and a larger rated load and permissible moment than SRS-M.

Specification Table⇒ **A1-158**

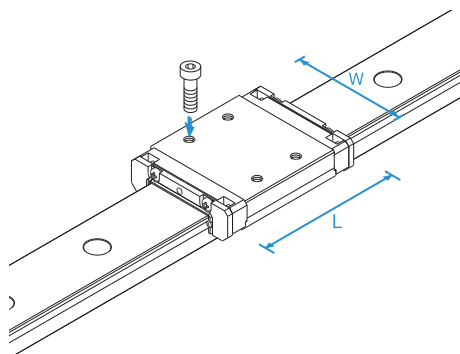

Model SRS-N

Compared with model SRS-M, it has a longer total LM block length (L) and a higher load rating and permissible moment.

Specification Table⇒ **A1-154**

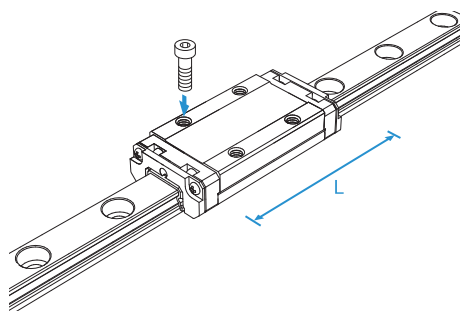

Model SRS-WN

Compared with Model SRS-WM, it has a longer total LM block length (L) and a higher load rating and permissible moment.

Specification Table⇒ **A1-158**

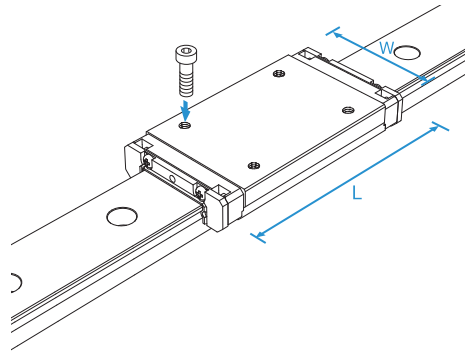

SRS-G

Specification Table⇒ **A1-154 to A1-160**

The SRS-G, a model equipped with uncaged, full-complement bearings, is also available. Due to its cageless design, however, the SRS-G's dynamic load rating is lower than that of standard SRS models. For specific data, please refer to the dimension tables in this catalog.

Flatness of the LM Rail and the LM Block Mounting Surface

Since the Model SRS has Gothic-arch grooves, any precision errors in the mounting surface may negatively affect its operability. Therefore, we recommend using SRS on mounting surfaces made with high precision.

Table1 Flatness of the LM Rail and the LM Block Mounting Surface

Unit: mm

Model No.	Flatness error
SRS 5	0.015/200
SRS 7	0.025/200
SRS 9	0.035/200
SRS 12	0.050/200
SRS 15	0.060/200
SRS 20	0.070/200
SRS 25	0.070/200

Note 1) As many factors can affect the mounting precision, we recommend using values 70% or less than those shown.

Note 2) The above figures apply to normal clearances. When using two or more rails with C1 clearance, we recommend using values 50% or less than those shown.

Models SRS-S, SRS-M and SRS-N

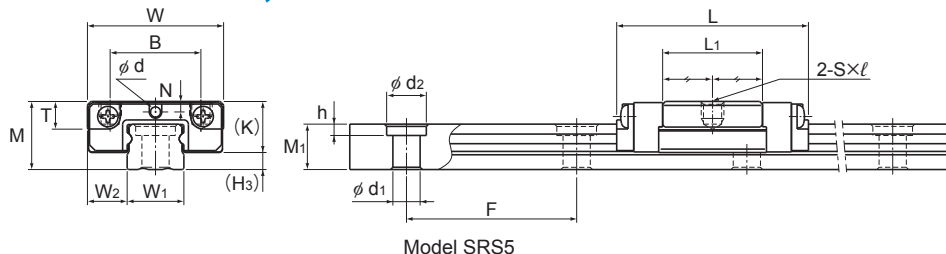

Model SRS5

Model No.	Outer dimensions			LM block dimensions								H ₃	
	Height	Width	Length	B	C	S×ℓ	L ₁	T	K	N	d		Greasing hole
	M	W	L										
SRS 5M SRS 5GM	6	12	16.9	8	—	M2×1.5	8.8	1.7	4.5	0.93	0.8	1.5	
SRS 5N SRS 5GN	6	12	20.1	8	—	M2×1.5	12	1.7	4.5	0.93	0.8	1.5	
SRS 7S SRS 7GS	8	17	19	12	—	M2×2.3	9	3.3	6.7	1.6	1.2	1.3	
SRS 7M SRS 7GM	8	17	23.4	12	8	M2×2.3	13.4	3.3	6.7	1.6	1.2	1.3	
SRS 7N SRS 7GN	8	17	31	12	13	M2×2.3	21	3.3	6.7	1.6	1.2	1.3	
SRS 9XS SRS 9XGS	10	20	21.5	15	—	M3×2.8	10.5	4.5	8.5	2.4	1.6	1.5	
SRS 9XM SRS 9XGM	10	20	30.8	15	10	M3×2.8	19.8	4.5	8.5	2.4	1.6	1.5	
SRS 9XN SRS 9XGN	10	20	40.8	15	16	M3×2.8	29.8	4.5	8.5	2.4	1.6	1.5	
SRS 12S SRS 12GS	13	27	25	20	—	M3×3.2	11.2	5.7	11	3	2	2.1	
SRS 12M SRS 12GM	13	27	34.4	20	15	M3×3.2	20.6	5.7	11	3	2	2.1	
SRS 12N SRS 12GN	13	27	47.1	20	20	M3×3.2	33.3	5.7	11	3	2	2.1	

Note) Since stainless steel is used in the LM block, LM rail and balls, these models are highly resistant to corrosion and environment.
The SRS-G is equipped with uncaged, full-complement bearings.
Using a greasing hole other than for greasing may cause damage.

Model number coding

2 SRS12M QZ UU C1 +220L P M -II

Model No. With QZ Lubricator Contamination protection accessory symbol (*2) LM rail length (in mm) Stainless steel LM rail Symbol for No. of rails used on the same plane (*5)

No. of LM blocks used on the same rail (*1) Radial clearance symbol (*3) Normal (No symbol)/Light preload (C1) Accuracy symbol (*4) Normal grade (No Symbol)/High accuracy grade (H) Precision grade (P)

(*1) No symbol for 1 LM block. (*2) See contamination protection accessories on **A1-516**. (*3) See **A1-71**. (*4) See **A1-83**. (*5) See **A1-13**.

Note) This model number indicates that a single-rail unit constitutes one set. (i.e., required number of sets when 2 rails are used in parallel is 2 at a minimum.) Those models equipped with QZ Lubricator cannot have a grease nipple. When desiring a grease nipple for a model attached with QZ, contact THK.

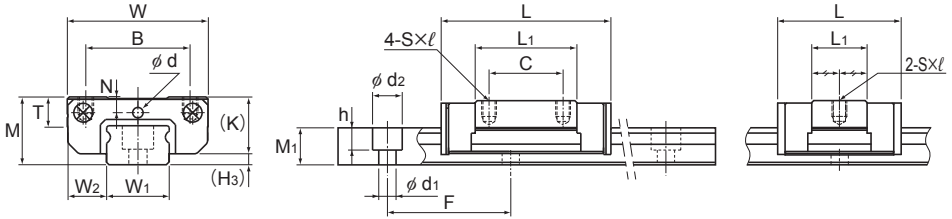

Models SRS7M/N, 9XM/XN, 12M/N

Models SRS7S, 9XS, 12S
Unit: mm

LM rail dimensions						Basic load rating		Static permissible moment N·m*					Mass	
Width	Height	Pitch	Length*	C	C ₀	M _A		M _B		M _C	LM block	LM rail		
						1 block	Double blocks	1 block	Double blocks	1 block			kg	kg/m
W ₁	W ₂	M ₁	F	d ₁ × d ₂ × h	Max	kN	kN	1 block	Double blocks	1 block	Double blocks	1 block	kg	kg/m
5 ⁰ _{-0.02}	3.5	4	15	2.4 × 3.5 × 1	220	0.439 0.366	0.468 0.527	0.74 0.79	5.11 5.76	0.86 0.94	5.99 6.91	1.21 1.37	0.002	0.13
5 ⁰ _{-0.02}	3.5	4	15	2.4 × 3.5 × 1	220	0.515 0.448	0.586 0.703	1.12 1.34	7.45 8.82	1.31 1.57	8.73 10.3	1.52 1.83	0.003	0.13
7 ⁰ _{-0.02}	5	4.7	15	2.4 × 4.2 × 2.3	480	1.09 0.946	0.964 1.16	1.60 1.96	12.6 14.7	1.83 2.25	14.5 16.9	3.73 4.49	0.005	0.25
7 ⁰ _{-0.02}	5	4.7	15	2.4 × 4.2 × 2.3	480	1.51 1.16	1.29 1.54	3.09 3.61	17.2 25.5	3.69 4.14	17.3 29.4	5.02 6.57	0.009	0.25
7 ⁰ _{-0.02}	5	4.7	15	2.4 × 4.2 × 2.3	480	2.01 1.63	2.31 2.51	7.77 8.08	43.2 46.9	8.96 9.32	50.0 54.2	8.96 9.72	0.012	0.25
9 ⁰ _{-0.02}	5.5	5.5	20	3.5 × 6 × 3.3	1240	1.78 1.37	1.53 1.53	3.15 2.85	22.2 22.6	3.61 3.27	25.6 26	7.04 7.04	0.009	0.36
9 ⁰ _{-0.02}	5.5	5.5	20	3.5 × 6 × 3.3	1240	2.69 2.22	2.75 3.06	9.31 9.87	52.2 57.9	10.7 11.4	60.3 66.9	12.7 14.1	0.016	0.36
9 ⁰ _{-0.02}	5.5	5.5	20	3.5 × 6 × 3.3	1240	3.48 2.94	3.98 4.59	18.7 21.1	96.5 111	21.6 24.4	112 128	18.3 21.1	0.024	0.36
12 ⁰ _{-0.02}	7.5	7.5	25	3.5 × 6 × 4.5	2000	2.70 2.07	2.10 2.10	4.62 4.17	37.5 38.1	4.62 4.17	37.5 38.1	13.8 13.8	0.017	0.65
12 ⁰ _{-0.02}	7.5	7.5	25	3.5 × 6 × 4.5	2000	4.00 3.36	3.53 3.55	12.0 12.1	78.5 79.0	12.0 12.1	78.5 79.0	23.1 23.2	0.027	0.65
12 ⁰ _{-0.02}	7.5	7.5	25	3.5 × 6 × 4.5	2000	5.82 4.72	5.30 6.83	28.4 34.8	151 195	28.4 34.8	151 195	34.7 44.7	0.049	0.65

Note1) The maximum length under "Length*" indicates the standard maximum length of an LM rail. (See **A1-162**.)

Static permissible moment* 1 block: the static permissible moment with one LM block

Double blocks: static permissible moment when two LM blocks are in close contact with each other

Total block length L : The total block length L shown in the table is the length with the dust proof parts, code UU or SS. If other contamination protection accessories or lubricant equipment are installed, the total block length will increase.

(See **A1-491** or **A1-512**)

For the SRS5M and SRS5N LM guide, the balls will fall out of the block if it is removed from the rail.

To secure the LM rail of model SRS5M, use cross-recessed head screws for precision equipment (No. 0 pan head screw, class 1) M2.

Note2) The basic load rating in the dimension table is for a load in the radial direction. Use Table7 on **A1-59** to calculate the load rating for loads in the reverse radial direction or lateral direction.

- Reference bolt tightening torque when mounting an LM block for model SRS 5 and 7 are shown in the table below.

Reference tightening torque

Model No.	Model No. of screw	Screw depth (mm)	Reference tightening torque(N·m)*
SRS 5	M2	1.5	0.4
SRS 7	M2	2.3	0.4

*Tightening above the tightening torque affects accuracy.
Be sure to tighten at or below the defined tightening torque.

Models SRS-S, SRS-M and SRS-N

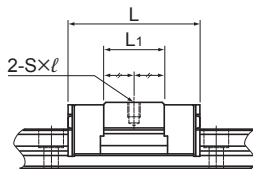

Model SRS15S

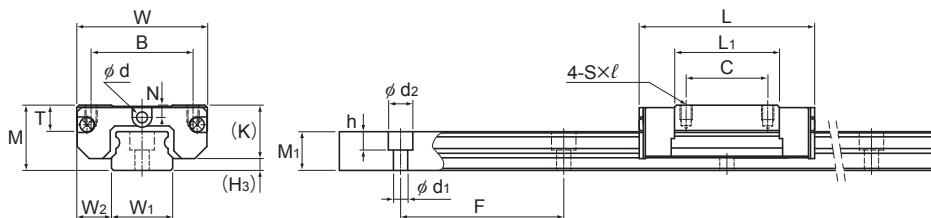

Models SRS15M/N, 20M, 25M

Model No.	Outer dimensions			LM block dimensions										Greasing hole	Grease nipple	H ₃
	Height	Width	Length	B	C	S × l	L ₁	T	K	N	E	d				
	M	W	L	B	C	S × l	L ₁	T	K	N	E	d				
SRS 15S SRS 15GS	16	32	32	25	—	M3 × 3.5	14.7	6.5	13.3	3	—	4	3	—	PB107	2.7
SRS 15M SRS 15GM	16	32	43	25	20	M3 × 3.5	25.7	6.5	13.3	3	—	4	3	—	PB107	2.7
SRS 15N SRS 15GN	16	32	60.8	25	25	M3 × 3.5	43.5	6.5	13.3	3	—	4	3	—	PB107	2.7
SRS 20M SRS 20GM	20	40	50	30	25	M4 × 6	34	9	16.6	4	—	3.5	3	—	PB107	3.4
SRS 25M SRS 25GM	25	48	77	35	35	M6 × 7	56	11	20	5	—	4	4	—	PB1021B	5

Note) Since stainless steel is used in the LM block, LM rail and balls, these models are highly resistant to corrosion and environment.
 The SRS-G is equipped with uncaged, full-complement bearings.
 For the SRS15S/M/N, 20M, and 25M, if a grease nipple is required, please specify upon ordering.
 Using a greasing hole other than for greasing may cause damage.

Model number coding

2 SRS20M QZ UU C1 +220L P M - II

Model No. With QZ Lubricator Contamination protection accessory symbol (*2) LM rail length (in mm) Stainless steel LM rail Symbol for No. of rails used on the same plane (*5)
 No. of LM blocks used on the same rail (*1) Radial clearance symbol (*3) Normal (No symbol)/Light preload (C1) Accuracy symbol (*4)
 Normal grade (No Symbol)/High accuracy grade (H) Precision grade (P)
 (*1) No symbol for 1 LM block. (*2) See contamination protection accessories on **A1-516**.
 (*3) See **A1-71**. (*4) See **A1-83**. (*5) See **A1-13**.

Note) This model number indicates that a single-rail unit constitutes one set. (i.e., required number of sets when 2 rails are used in parallel is 2 at a minimum.)
 Those models equipped with QZ Lubricator cannot have a grease nipple. When desiring a grease nipple for a model attached with QZ, contact THK.

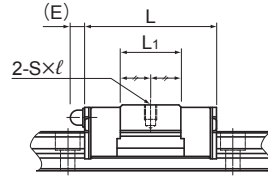

Model SRS15GS

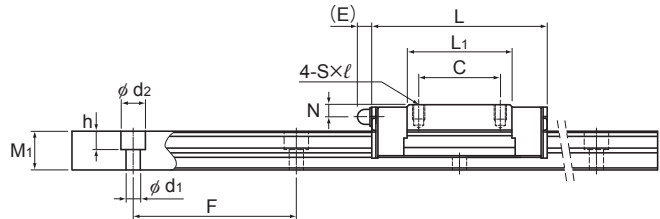
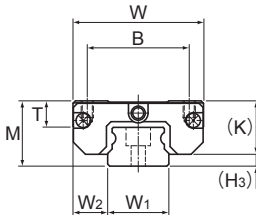

Models SRS15GM/GN,20GM,25GM

Unit: mm

LM rail dimensions							Basic load rating		Static permissible moment N*m*					Mass	
Width	Height	Pitch	Length*	C	C ₀	M _A	M _B	M _C	1 block		Double blocks		LM block	LM rail	
									W ₁	W ₂	M ₁	F			d ₁ × d ₂ × h
15 ⁰ _{-0.02}	8.5	9.5	40	3.5 × 6 × 4.5	2000	4.50	3.39	9.54	77.5	9.54	77.5	24.1	0.033	0.96	
						4.01	4.24	12.6	92.7	12.6	92.7	30.1			
15 ⁰ _{-0.02}	8.5	9.5	40	3.5 × 6 × 4.5	2000	6.66	5.7	26.2	154	26.2	154	40.4	0.047	0.96	
						5.59	5.72	24.8	158	24.8	158	40.6			
15 ⁰ _{-0.02}	8.5	9.5	40	3.5 × 6 × 4.5	2000	9.71	8.55	59.7	312	59.7	312	60.7	0.095	0.96	
						8.27	11.9	44.7	433	82.3	433	84.5			
20 ⁰ _{-0.03}	10	11	60	6 × 9.5 × 8	1800	7.75	9.77	54.3	296	62.4	341	104	0.11	1.68	
						5.95	9.4	44.7	242	53.3	289	91.4			
23 ⁰ _{-0.03}	12.5	15	60	7 × 11 × 9	1800	16.5	20.2	177	932	177	932	248	0.24	2.6	
						13.3	22.3	181	962	181	962	255			

Note1) The maximum length under "Length*" indicates the standard maximum length of an LM rail. (See **A1-162**.)

Static permissible moment* 1 block: the static permissible moment with one LM block

Double blocks: static permissible moment when two LM blocks are in close contact with each other

Total block length L : The total block length L shown in the table is the length with the dust proof parts, code UU or SS. If other contamination protection accessories or lubricant equipment are installed, the total block length will increase.

(See **A1-491** or **A1-512**)

Note2) The basic load rating in the dimension table is for a load in the radial direction. Use Table7 on **A1-59** to calculate the load rating for loads in the reverse radial direction or lateral direction.

Models SRS-WS, SRS-WM and SRS-WN

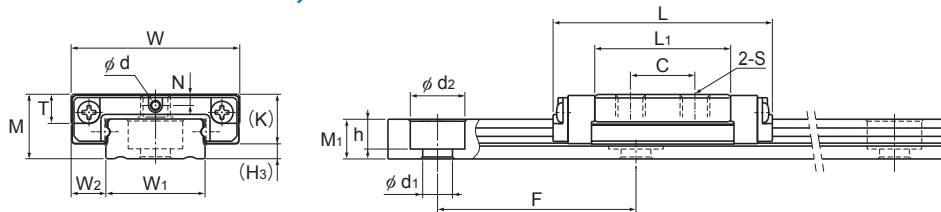

Model SRS5

Model No.	Outer dimensions			LM block dimensions								Greasing hole	H ₃
	Height	Width	Length	B	C	S × ℓ	L ₁	T	K	N	d		
	M	W	L										
SRS 5WM SRS 5WGM	6.5	17	22.1	—	6.5	M3 through	13.7	2.7	5	1.1	0.8	1.5	
SRS 5WN SRS 5WGN	6.5	17	28.1	—	11	M3 through	19.7	2.7	5	1.1	0.8	1.5	
SRS 7WS SRS 7WGS	9	25	22.5	19	—	M3 × 2.8	11.9	3.8	7.2	1.8	1.2	1.8	
SRS 7WM SRS 7WGM	9	25	31	19	10	M3 × 2.8	20.4	3.8	7.2	1.8	1.2	1.8	
SRS 7WN SRS 7WGN	9	25	40.9	19	17	M3 × 2.8	30.3	3.8	7.2	1.8	1.2	1.8	
SRS 9WS SRS 9WGS	12	30	26.5	21	—	M3 × 2.8	14.5	4.9	9.1	2.3	1.6	2.9	
SRS 9WM SRS 9WGM	12	30	39	21	12	M3 × 2.8	27	4.9	9.1	2.3	1.6	2.9	
SRS 9WN SRS 9WGN	12	30	50.7	23	24	M3 × 2.8	38.7	4.9	9.1	2.3	1.6	2.9	
SRS 12WS SRS 12WGS	14	40	30.5	28	—	M3 × 3.5	16.9	5.7	11	3	2	3	
SRS 12WM SRS 12WGM	14	40	44.5	28	15	M3 × 3.5	30.9	5.7	11	3	2	3	
SRS 12WN SRS 12WGN	14	40	59.5	28	28	M3 × 3.5	45.9	5.7	11	3	2	3	

Note) Since stainless steel is used in the LM block, LM rail and balls, these models are highly resistant to corrosion and environment.
The SRS-G is equipped with uncaged, full-complement bearings.
Using a greasing hole other than for greasing may cause damage.

Model number coding

2	SRS12WM	QZ	UU	C1	+470L	P	M	-II
No. of LM blocks used on the same rail (*1)	Model No.	With QZ Lubricator	Contamination protection accessory symbol (*2)	Radial clearance symbol (*3) Normal (No symbol)/ Light preload (C1)	LM rail length (in mm)	Stainless steel LM rail	Accuracy symbol (*4) Normal grade (No Symbol)/High accuracy grade (H) Precision grade (P)	Symbol for No. of rails used on the same plane (*5)

(*1) No symbol for 1 LM block. (*2) See contamination protection accessories on **A1-516**.

(*3) See **A1-71**. (*4) See **A1-83**. (*5) See **A1-13**.

Note) This model number indicates that a single-rail unit constitutes one set. (i.e., required number of sets when 2 rails are used in parallel is 2 at a minimum.)
Those models equipped with QZ Lubricator cannot have a grease nipple. When desiring a grease nipple for a model attached with QZ, contact THK.

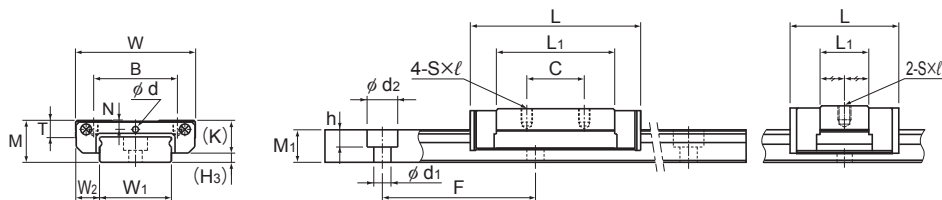

Models SRS7WM/WN,9WM/WN,12WM/WN

Models SRS7 to 12WS
Unit: mm

LM rail dimensions								Basic load rating		Static permissible moment $N \cdot m^*$					Mass	
Width			Height	Pitch		Length*	C	C_0	M_A		M_B		M_C	LM block	LM rail	
W_1	W_2	W_3	M_1	F	$d_1 \times d_2 \times h$	Max	kN	kN						kg	kg/m	
									1 block	Double blocks	1 block	Double blocks	1 block			
10 ⁰ _{-0.02}	3.5	—	4	20	3×5.5×3	220	0.584 0.498	0.703 0.82	1.57 1.79	9.59 11.1	1.83 2.15	11.24 13.3	3.58 4.18	0.005	0.27	
10 ⁰ _{-0.02}	3.5	—	4	20	3×5.5×3	220	0.746 0.64	0.996 1.17	3.01 3.54	16.8 19.6	3.53 4.15	19.3 23	5.08 5.97	0.007	0.27	
14 ⁰ _{-0.02}	5.5	—	5.2	30	3.5×6×3.2	480	1.38 1.06	1.35 1.35	2.89 2.58	19.6 20.0	3.32 2.96	22.7 23.1	9.95 9.95	0.011	0.56	
14 ⁰ _{-0.02}	5.5	—	5.2	30	3.5×6×3.2	480	2.01 1.63	1.94 2.51	6.47 8.87	36.4 51.5	7.71 10.2	42.3 59.5	14.33 20.3	0.018	0.56	
14 ⁰ _{-0.02}	5.5	—	5.2	30	3.5×6×3.2	480	2.56 2.12	3.28 3.66	15.0 16.6	78.9 87.7	17.4 19.2	91.2 101	24.2 27	0.026	0.56	
18 ⁰ _{-0.02}	6	—	7.5	30	3.5×6×4.5	1430	2.03 1.73	1.84 2.14	4.49 5.15	32.1 36.9	5.15 5.92	38.9 42.6	17.4 20.2	0.018	1.01	
18 ⁰ _{-0.02}	6	—	7.5	30	3.5×6×4.5	1430	3.29 2.67	3.34 3.35	14.0 13.9	78.6 69.7	16.2 16.6	91.0 96.7	31.5 31.7	0.031	1.01	
18 ⁰ _{-0.02}	6	—	7.5	30	3.5×6×4.5	1430	4.20 3.48	4.37 5.81	25.1 33.2	130 172	29.1 40	151 208	41.3 54.9	0.049	1.01	
24 ⁰ _{-0.02}	8	—	8.5	40	4.5×8×4.5	2000	3.58 3.05	3.15 3.68	9.77 11.1	63 72.6	9.77 11.1	63 72.6	39.5 46.2	0.034	1.52	
24 ⁰ _{-0.02}	8	—	8.5	40	4.5×8×4.5	2000	5.48 4.46	5.3 5.32	26.4 25.7	143 146	26.4 25.7	143 146	66.5 66.8	0.055	1.52	
24 ⁰ _{-0.02}	8	—	8.5	40	4.5×8×4.5	2000	7.13 5.93	7.07 9.46	49.2 64.7	249 332	49.2 64.7	249 332	88.7 119	0.091	1.52	

Note1) The maximum length under "Length*" indicates the standard maximum length of an LM rail. (See [A1-162](#).)

Static permissible moment* 1 block: the static permissible moment with one LM block

Double blocks: static permissible moment when two LM blocks are in close contact with each other
Total block length L : The total block length L shown in the table is the length with the dust proof parts, code UU or SS.
If other contamination protection accessories or lubricant equipment are installed, the total block length will increase.
(See [A1-491](#) or [A1-512](#))

For the SRS5WM and SRS5WN, the balls will fall out of the block if it is removed from the rail.

Note2) The basic load rating in the dimension table is for a load in the radial direction. Use Table7 on [A1-59](#) to calculate the load rating for loads in the reverse radial direction or lateral direction.

- Reference bolt tightening torque when mounting an LM block for model SRS 5 and 7W are shown in the table below.

Reference tightening torque

Model No.	Model No. of screw	Screw depth (mm)	Reference tightening torque(N·m)*
SRS 5W	M3	2.3	0.4
SRS 7W	M3	2.8	0.4

*Tightening above the tightening torque affects accuracy.
Be sure to tighten at or below the defined tightening torque.

Models SRS-WS, SRS-WM and SRS-WN

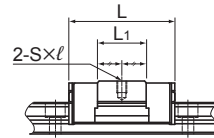

Model SRS15WS

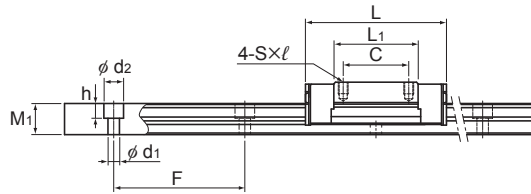
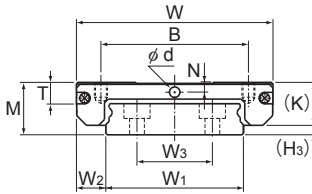

Model SRS15WM/WN

Model No.	Outer dimensions			LM block dimensions										Greasing hole	Grease nipple	H ₃
	Height	Width	Length	B	C	S × l	L ₁	T	K	N	E	d				
	M	W	L													
SRS 15WS	16	60	41.5	45	—	M4 × 4.5	24.9	6.5	13.3	3	—	3	—	—	PB107	2.7
SRS 15WGS																
SRS 15WM	16	60	55.5	45	20	M4 × 4.5	38.9	6.5	13.3	3	—	3	—	—	PB107	2.7
SRS 15WGM																
SRS 15WN	16	60	74.5	45	35	M4 × 4.5	57.9	6.5	13.3	3	—	3	—	—	PB107	2.7
SRS 15WGN																

Note) Since stainless steel is used in the LM block, LM rail and balls, these models are highly resistant to corrosion and environment.

The SRS-G is equipped with uncaged, full-complement bearings.

For the SRS15WS/WM/WN, if a grease nipple is required, please specify upon ordering.

Using a greasing hole other than for greasing may cause damage.

Model number coding

2 SRS15WM QZ UU C1 +550L P M -II

Model No.

With QZ
Lubricator

Contamination
protection
accessory
symbol (*2)

LM rail length
(in mm)

Stainless
steel
LM rail

Symbol for
No. of rails used
on the same plane (*5)

No. of LM blocks
used on the same rail (*1)

Radial clearance symbol (*3)
Normal (No symbol)/
Light preload (C1)

Accuracy symbol (*4)
Normal grade (No Symbol)/High accuracy grade (H)
Precision grade (P)

(*1) No symbol for 1 LM block. (*2) See contamination protection accessories on **A1-516**.

(*3) See **A1-71**. (*4) See **A1-83**. (*5) See **A1-13**.

Note) This model number indicates that a single-rail unit constitutes one set. (i.e., required number of sets when 2 rails are used in parallel is 2 at a minimum.) Those models equipped with QZ Lubricator cannot have a grease nipple. When desiring a grease nipple for a model attached with QZ, contact THK.

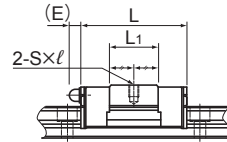

Model SRS15WGS

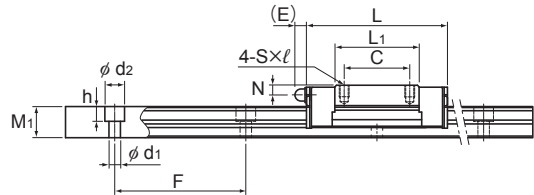
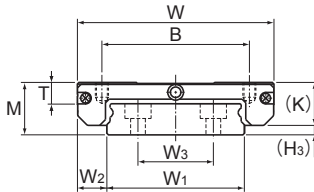

Model SRS15WGM/WGN

Unit: mm

	LM rail dimensions							Basic load rating		Static permissible moment N·m*					Mass	
	Width	Height	Pitch	Length*	C	C ₀	M _A	M _B	M _C	LM block	LM rail					
												kg	kg/m			
	W ₁	W ₂	W ₃	M ₁	F	d ₁ × d ₂ × h	Max	kN	kN	1 block	Double blocks	1 block	Double blocks	1 block		
42 ⁰ _{-0.02}	9	23	9.5	40	4.5 × 8 × 4.5	2000	6.64	5.94	25.4	158	25.4	158	123	0.087	2.87	
42 ⁰ _{-0.02}	9	23	9.5	40	4.5 × 8 × 4.5	2000	5.59	6.78	29	178	29	178	140	0.13	2.87	
42 ⁰ _{-0.02}	9	23	9.5	40	4.5 × 8 × 4.5	2000	9.12	8.55	51.2	290	51.2	290	176	0.201	2.87	
42 ⁰ _{-0.02}	9	23	9.5	40	4.5 × 8 × 4.5	2000	7.43	8.59	52.7	293	52.7	293	178			
							12.4	12.1	106	532	106	532	250			
							9.87	15.3	133	671	133	671	317			

Note) The maximum length under "Length * " indicates the standard maximum length of an LM rail. (See [A1-162](#).)

Static permissible moment* 1 block: the static permissible moment with one LM block

Double blocks: static permissible moment when two LM blocks are in close contact with each other

Total block length L

: The total block length L shown in the table is the length with the dust proof parts, code UU or SS. If other contamination protection accessories or lubricant equipment are installed, the total block length will increase.

(See [A1-491](#) or [A1-512](#))

Standard Length and Maximum Length of the LM Rail

Table2 shows the standard lengths and the maximum lengths of model SRS variations. If the maximum length of the desired LM rail exceeds them, jointed rails will be used. Contact THK for details. For special rail lengths, it is recommended to use a value corresponding to the G,g dimension from the table. As the G,g dimension increases, this portion becomes less stable, and the accuracy performance is severely impacted.

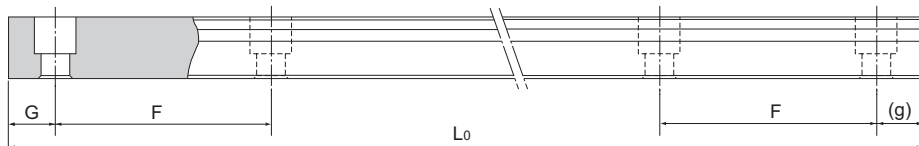

Table2 Standard Length and Maximum Length of the LM Rail for Model SRS

Unit: mm

Model No.	SRS 5	SRS 5W	SRS 7	SRS 7W	SRS 9	SRS 9W	SRS 12	SRS 12W	SRS 15	SRS 15W	SRS 20	SRS 25	
LM rail standard length (L_0)	40	50	40	50	55	50	70	70	70	110	220	220	
	55	70	55	80	75	80	95	110	110	150	280	280	
	70	90	70	110	95	110	120	150	150	190	340	340	
	100	110	85	140	115	140	145	190	190	230	460	460	
	130	130	100	170	135	170	170	230	230	270	640	640	
	160	150	115	200	155	200	195	270	270	310	880	880	
			170	130	260	175	260	220	310	310	430	1000	1000
				290	195	290	245	390	390	350	550		
					275	320	270	470	390	390	670		
					375		320	550	430	430	790		
							370		470	470			
							470		550	550			
							570		670	670			
								870	870				
Standard pitch F	15	20	15	30	20	30	25	40	40	40	60	60	
G,g	5	5	5	10	7.5	10	10	15	15	15	20	20	
Max length	220	220	480	480	1240	1430	2000	2000	2000	2000	1800	1800	

Note1) The maximum length varies with accuracy grades. Contact THK for details.

Note2) If jointed rails are not allowed and a greater length than the maximum values above is required, contact THK.



✓ Excellente service

✓ Klantspecifieke assemblage

✓ Voorraadhoudend

✓ Leveringsgraad 99,5%

Gildetrom 25 3905 TB Veenendaal **Nederland**

T: +31 (0)318-554615 | E: info@lmsystems.nl

www.lmsystems.nl

Leuvensesteenweg 613 | B-1930 Zaventem **België**

T: +32 (0)2 252 4745 | E: info@lmsystems.be

www.lmsystems.be