



UW LINEAIR SPECIALIST

VOOR IEDERE INDUSTRIËLE TOEPASSING
EEN INDIVIDUELE OPLOSSING



Excellente service



Klantspecifieke assemblage



Voorraadhoudend



Leveringsgraad 99,5%

Nederland

T: +31 (0)318-554615

E: info@lmsystems.nl

www.lmsystems.nl

België

T: +32 (0)2 252 4745

E: info@lmsystems.be

www.lmsystems.be

SHW



Caged Ball LM Guide Wide Rail Model SHW

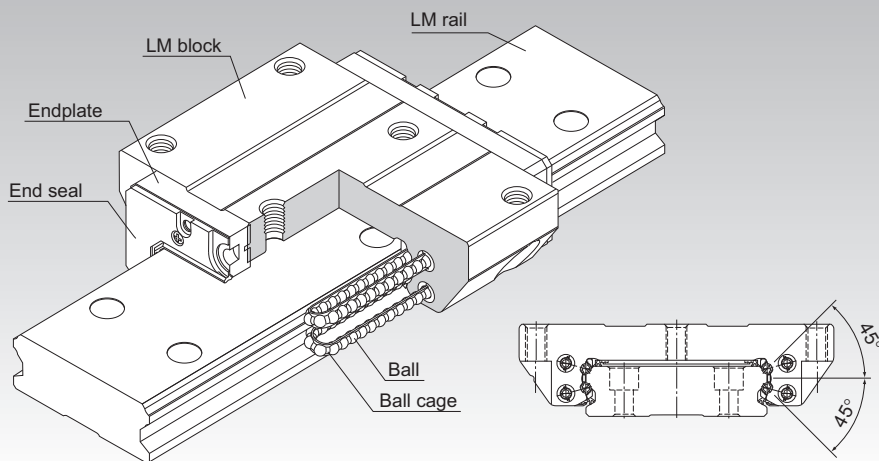

*For the ball cage, see **A1-88**.

Point of Selection **A1-10**

Point of Design **A1-454**

Options **A1-477**

Model No. **A1-543**

Precautions on Use **A1-549**

Accessories for Lubrication **A24-1**

Mounting Procedure and Maintenance **B1-89**

Equivalent moment factor **A1-43**

Rated Loads in All Directions **A1-59**

Equivalent factor in each direction **A1-61**

Radial Clearance **A1-71**

Accuracy Standards **A1-77**

Shoulder Height of the Mounting Base and the Corner Radius **A1-467**

Permissible Error of the Mounting Surface **A1-471**

Dimensions of Each Model with an Option Attached **A1-491**

Structure and Features

A wide and highly rigid LM Guide that uses ball cages to achieve low noise, long-term maintenance-free operation and high speed.

[Wide, Low Center of Gravity]

Model SHW, which has a wide LM rail and a low center of gravity, is optimal for locations requiring space saving and large M_o moment rigidity.

[4-way Equal Load]

Each row of balls is placed at a contact angle of 45° so that the rated loads applied to the LM block are uniform in the four directions (radial, reverse radial and lateral directions), enabling the LM Guide to be used in all orientations and in extensive applications.

[Self-adjustment Capability]

The self-adjustment capability through front-to-front configuration of THK's unique circular-arc grooves (DF set) enables a mounting error to be absorbed even under a preload, thus to achieve highly accurate, smooth straight motion.

[Low Dust Generation]

Use of ball cages eliminates friction between balls and retains lubricant, thus achieving low dust generation.

Types and Features

Model SHW-CA

The flange of the LM block has tapped holes.
Can be mounted from the top or the bottom.

Specification Table⇒ [A1-142](#)

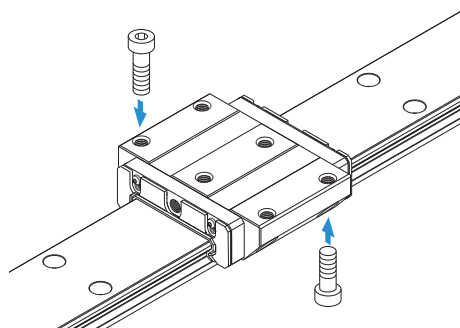

Model SHW-CR

The LM block has tapped holes.

Specification Table⇒ [A1-144](#)

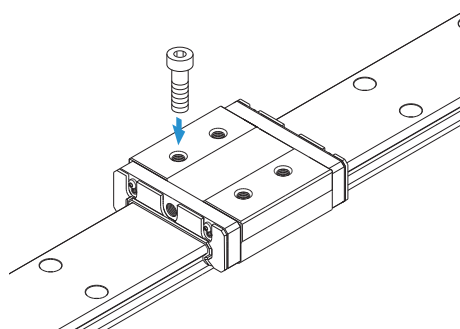

Model SHW-CA

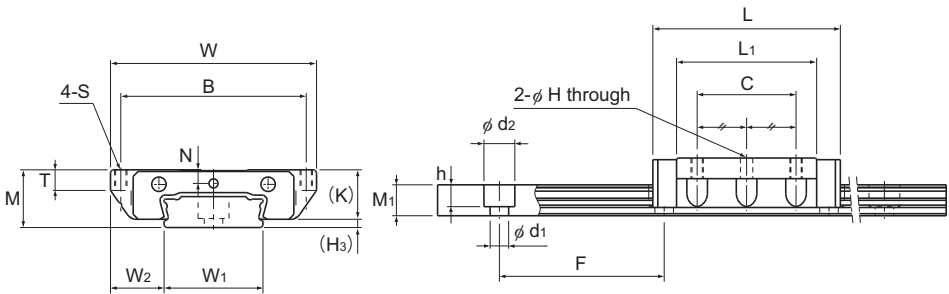

Models SHW12CAM and SHW14CAM

Model No.	Outer dimensions			LM block dimensions								H ₃
	Height	Width	Length	B	C	S	H	L ₁	T	K	N	
	M	W	L									
SHW 12CAM	12	40	37	35	18	M3	2.5	27	4	10	2.8	2
SHW 14CAM	14	50	45.5	45	24	M3	2.5	34	5	12	3.3	2
SHW 17CAM	17	60	51	53	26	M4	3.3	38	6	14.5	4	2.5
SHW 21CA	21	68	59	60	29	M5	4.4	43.6	8	17.7	5	3.3
SHW 27CA	27	80	72.8	70	40	M6	5.3	56.6	10	23.5	6	3.5
SHW 35CA	35	120	107	107	60	M8	6.8	83	14	31	7.6	4
SHW 50CA	50	162	141	144	80	M10	8.6	107	18	46	14	4

Note) The M in the model number symbol indicates that the LM block, LM rail and balls are made of stainless steel. The stainless steel provides excellent corrosion and environmental resistance.

Model number coding

SHW17 CA 2 QZ UU C1 M +580L P M -II

Model number

Type of LM block

With QZ Lubricator

Contamination protection accessory symbol (*1)

Stainless steel LM block

LM rail length (in mm)

Stainless steel LM rail

Symbol for No. of rails used on the same plane (*4)

No. of LM blocks used on the same rail

Radial clearance symbol (*2)
Normal (No symbol)
Light preload (C1)
Medium preload (C0)

Accuracy symbol (*3)
Normal grade (No Symbol)/High accuracy grade (H)
Precision grade (P)/Super precision grade (SP)
Ultra precision grade (UP)

(*1) See contamination protection accessory on **A1-516**. (*2) See **A1-71**. (*3) See **A1-77**. (*4) See **A1-13**.

Note) This model number indicates that a single-rail unit constitutes one set. (i.e., required number of sets when 2 rails are used in parallel is 2 at a minimum.)

Those models equipped with QZ Lubricator cannot have a grease nipple. When desiring a grease nipple for a model attached with QZ, contact THK.

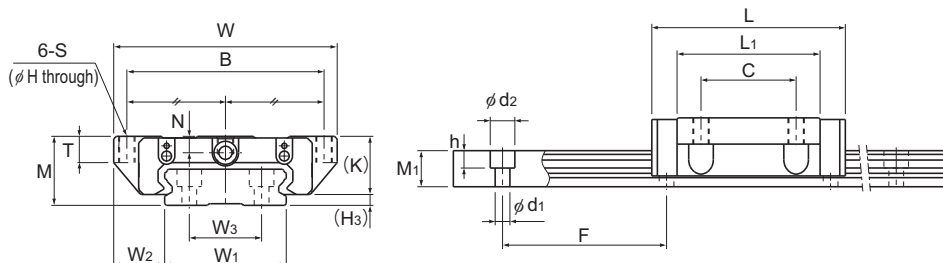

Models SHW17CAM and SHW21 to 50CA

Unit: mm

LM rail dimensions										Basic load rating		Static permissible moment kN·m*					Mass	
Width			Height	Pitch		Length*	C	C ₀	M _A		M _B		M _C	LM block	LM rail			
W ₁	W ₂	W ₃	M ₁	F	d ₁ × d ₂ × h	Max	kN	kN	1 block		Double blocks		1 block	kg	kg/m			
0	-0.05								1	Double	1	Double	1					
18	11	—	6.6	40	4.5 × 7.5 × 5.3	1230	4.31	5.66	0.0228	0.12	0.0228	0.12	0.0405	0.05	0.8			
24	13	—	7.5	40	4.5 × 7.5 × 5.3	1430	7.05	8.98	0.0466	0.236	0.0466	0.236	0.0904	0.1	1.23			
33	13.5	18	8.6	40	4.5 × 7.5 × 5.3	1800	7.65	10.18	0.0591	0.298	0.0591	0.298	0.164	0.15	1.9			
37	15.5	22	11	50	4.5 × 7.5 × 5.3	3000	8.24	12.8	0.0806	0.434	0.0806	0.434	0.229	0.24	2.9			
42	19	24	15	60	4.5 × 7.5 × 5.3	3000	16	22.7	0.187	0.949	0.187	0.949	0.455	0.47	4.5			
69	25.5	40	19	80	7 × 11 × 9	3000	35.5	49.2	0.603	3	0.603	3	1.63	1.4	9.6			
90	36	60	24	80	9 × 14 × 12	3000	70.2	91.4	1.46	7.37	1.46	7.37	3.97	3.7	15			

Note) The maximum length under "Length*" indicates the standard maximum length of an LM rail. (See [A1-146](#).)

Static permissible moment* 1 block: the static permissible moment with one LM block

Double blocks: static permissible moment when two LM blocks are in close contact with each other

Total block length L : The total block length L shown in the table is the length with the dust proof parts, code UU or SS. If other contamination protection accessories or lubrication equipment are installed, the total block length will increase.

(See [A1-491](#) or [A1-512](#))

Models SHW-CR and SHW-HR

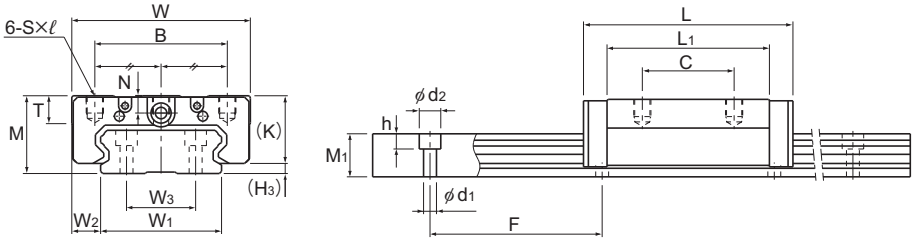

Models SHW27 to 50CR

Model No.	Outer dimensions			LM block dimensions							H ₃
	Height	Width	Length	B	C	S×ℓ	L ₁	T	K	N	
	M	W	L								
SHW 12CRM	12	30	37	21	12	M3×3.5	27	4	10	2.8	2
SHW 12HRM	12	30	50.4	21	24	M3×3.5	40.4	4	10	2.8	2
SHW 14CRM	14	40	45.5	28	15	M3×4	34	5	12	3.3	2
SHW 17CRM	17	50	51	29	15	M4×5	38	6	14.5	4	2.5
SHW 21CR	21	54	59	31	19	M5×6	43.6	8	17.7	5	3.3
SHW 27CR	27	62	72.8	46	32	M6×6	56.6	10	23.5	6	3.5
SHW 35CR	35	100	107	76	50	M8×8	83	14	31	7.6	4
SHW 50CR	50	130	141	100	65	M10×15	107	18	46	14	4

Note) The M in the model number symbol indicates that the LM block, LM rail and balls are made of stainless steel. The stainless steel provides excellent corrosion and environmental resistance.

Model number coding

SHW17	CR	2	QZ	KKHH	C1	M	+820L	P	M	-II
Model number	Type of LM block	No. of LM blocks used on the same rail	With QZ Lubricator	Contamination protection accessory symbol (*1)	Radial clearance symbol (*2) Normal (No symbol) Light preload (C1) Medium preload (C0)	Stainless steel LM block	LM rail length (in mm)	LM rail is made of stainless steel	Accuracy symbol (*3) Normal grade (No Symbol) High accuracy grade (H)/Precision grade (P) Super precision grade (SP)/Ultra precision grade (UP)	Symbol for No. of rails used on the same plane (*4)

(*1) See contamination protection accessory on **A1-516**. (*2) See **A1-71**. (*3) See **A1-77**. (*4) See **A1-13**.

Note) Those models equipped with QZ Lubricator cannot have a grease nipple. When desiring a grease nipple for a model attached with QZ, contact THK.

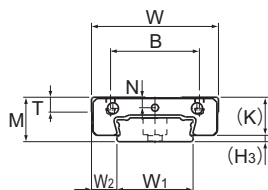

Models SHW12CRM, SHW12HRM and SHW14CRM

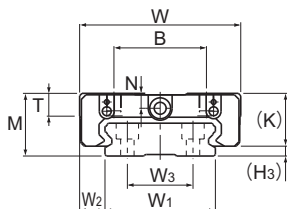
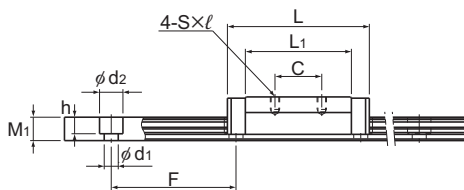

Models SHW17CRM and SHW21CRM

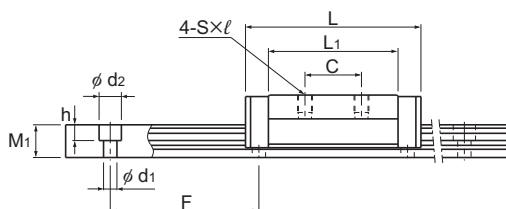

Unit: mm

LM rail dimensions							Basic load rating		Static permissible moment kN·m*					Mass	
Width W ₁ 0 -0.05	W ₂	W ₃	Height M ₁	Pitch F	Length* d ₁ ×d ₂ ×h Max	C kN	C ₀ kN	M _A		M _B		M _C	LM block kg	LM rail kg/m	
								1 block	Double blocks	1 block	Double blocks	1 block			
18	6	—	6.6	40	4.5×7.5×5.3	1230	4.31	5.66	0.0228	0.12	0.0228	0.12	0.0405	0.04	0.8
18	6	—	6.6	40	4.5×7.5×5.3	1230	5.56	8.68	0.0511	0.246	0.0511	0.246	0.0621	0.06	0.8
24	8	—	7.5	40	4.5×7.5×5.3	1430	7.05	8.98	0.0466	0.236	0.0466	0.236	0.0904	0.08	1.23
33	8.5	18	8.6	40	4.5×7.5×5.3	1800	7.65	10.18	0.0591	0.298	0.0591	0.298	0.164	0.13	1.9
37	8.5	22	11	50	4.5×7.5×5.3	3000	8.24	12.8	0.0806	0.434	0.0806	0.434	0.229	0.19	2.9
42	10	24	15	60	4.5×7.5×5.3	3000	16	22.7	0.187	0.949	0.187	0.949	0.455	0.36	4.5
69	15.5	40	19	80	7×11×9	3000	35.5	49.2	0.603	3	0.603	3	1.63	1.2	9.6
90	20	60	24	80	9×14×12	3000	70.2	91.4	1.46	7.37	1.46	7.37	3.97	3	15

Note) The maximum length under "Length*" indicates the standard maximum length of an LM rail. (See **A1-146**.)
 Static permissible moment* 1 block: the static permissible moment with one LM block

Double blocks: static permissible moment when two LM blocks are in close contact with each other
 Total block length L : The total block length L shown in the table is the length with the dust proof parts, code UU or SS.
 If other contamination protection accessories or lubricant equipment are installed, the total block length will increase.
 (See **A1-491** or **A1-512**)

Standard Length and Maximum Length of the LM Rail

Table1 shows the standard lengths and the maximum lengths of model SHW variations. If the maximum length of the desired LM rail exceeds them, jointed rails will be used. Contact THK for details. For special rail lengths, it is recommended to use a value corresponding to the G,g dimension from the table. As the G,g dimension increases, this portion becomes less stable, and the accuracy performance is severely impacted.

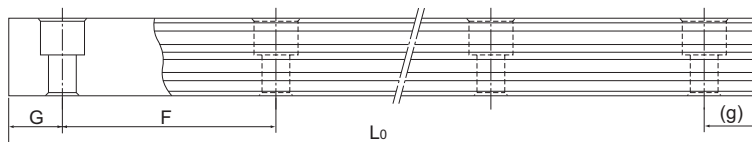

Table1 Standard Length and Maximum Length of the LM Rail for Model SHW

Unit: mm

Model No.	SHW 12	SHW 14	SHW 17	SHW 21	SHW 27	SHW 35	SHW 50
LM rail standard length (L ₀)	70	70	110	130	160	280	280
	110	110	190	230	280	440	440
	150	150	310	380	340	760	760
	190	190	470	480	460	1000	1000
	230	230	550	580	640	1240	1240
	270	270		780	820	1560	1640
	310	310					2040
	390	390					
	470	470					
		550					
	670						
Standard pitch F	40	40	40	50	60	80	80
G,g	15	15	15	15	20	20	20
Max length	1230	1430	1800	3000	3000	3000	3000

Note1) The maximum length varies with accuracy grades. Contact THK for details.

Note2) If jointed rails are not allowed and a greater length than the maximum values above is required, contact THK.

Note3) Models SHW12, 14 and 17 are made of stainless steel.

Greasing Hole

[Grease Nipple and Greasing Hole for Model SHW]

Model SHW does not have a grease nipple as standard. Installation of a grease nipple and the drilling of a greasing hole is performed at THK. When ordering SHW, indicate that the desired model requires a grease nipple or greasing hole. (For greasing hole dimensions and supported grease nipple types and dimensions, see Table2).

When using SHW under harsh conditions, use QZ Lubricator* (optional) or Laminated Contact Scraper LaCS* (optional).

Note1) Grease nipple is not available for models SHW12 and SHW14. They can have a greasing hole.

Note2) Using a greasing hole other than for greasing may cause damage.

Note3) For QZ Lubricator*, see [A1-509](#). For Laminated Contact Scraper LaCS*, see [A1-484](#).

Note4) When desiring a grease nipple for a model attached with QZ Lubricator, contact THK.

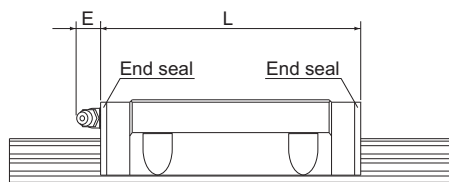

Fig.1 Dimensions of the Grease Nipple for Model SHW

Note) For the L dimension, see the corresponding specification table.

Table2 Table of Grease Nipple and Greasing Hole Dimensions

Unit: mm

Model No.	E	Grease nipple or greasing hole
SHW	12	— φ2.2 drilled hole
	14	— φ2.2 drilled hole
	17	5 PB107
	21	5.5 PB1021B
	27	12 B-M6F
	35	12 B-M6F
	50	16 B-PT1/8



✓ Excellente service

✓ Klantspecifieke assemblage

✓ Voorraadhoudend

✓ Leveringsgraad 99,5%

Gildetrom 25 3905 TB Veenendaal **Nederland**

T: +31 (0)318-554615 | E: info@lmsystems.nl

www.lmsystems.nl

Leuvensesteenweg 613 | B-1930 Zaventem **België**

T: +32 (0)2 252 4745 | E: info@lmsystems.be

www.lmsystems.be